

HERITAGE 150

OWNER'S MANUAL

MOTORCYCLE



WELCOME

Our scooter presents you with a challenge; a challenge to master a machine, a challenge to experience adventures, a challenge to be free. Unlike an automobile, there is no metal cage around you. There is only you and the road, linked together by a vehicle that responds to your every command like no other. Your reward...FREEDOM.

To answer this challenge, and to enjoy the adventures ahead, you should first become thoroughly familiar with this owner's manual.

As you read this manual, you will find information that is preceded by a NOTICE. This information is intended to help you avoid damages to your scooter, your body, property of others, and the environment.

IMPORTANT INFORMATION

1. Operator and Passenger

This scooter is designed to carry one operator and one passenger. Never exceed the manufacturer's recommended maximum weight capacity as shown on the loading label.

2. On-road Use Only

This scooter is designed to be used only on paved roads.

3. Read This Owner's Manual Carefully

Pay special attention to safety messages that appear throughout this manual. This manual should be considered a permanent part of your scooter, and should remain with the scooter when resold to subsequent owners.

TABLE OF CONTENTS

SAFETY INFORMATION

Important safety information.1-2

DESCRIPTION

Left & right views.....3

Instrument panel.....4-5

INSTRUMENT CONTROL

Main switch.....6

Steering lock.....7

Handlebar switches.....8

Fuel tank cap.....9

Seat lock.....9

Front/rear brake lever.....10

Rear storage/Helmet hoot.....11

PRE-OPERATION CHECKS

Pre-operation checks.....12

Brake.....13-14

Throttle.....15

Engine oil.....15

Tire.....16-17

Fitting.....18

Light switches.....18

Mirror.....18

Fuel.....19

OPERATION

Correct operation.....20

Starting off.....21

Acceleration.....22

Parking.....22

Break-in period.....23

PERIODIC MAINTENANCE AND REPAIR

Periodic maintenance.....24

Maintenance chart.....25

Engine oil.....26-27

Gear oil replacement.....28

Cleaning air filter.....29

Spark plug inspection.....30

Brake lever adjustment.....31

Brake fluid check.....32

Brake fluid replacement.....33

Cable inspection.....33

Brake lever lubrication.....34

Center stand lubrication.....34

Front fork inspection.....35

Steering inspection.....36

Fuse replacement.....37

Battery.....38

Electric circuit diagram.....39

Major technical parameters.....40

SAFETY INFORMATION

Important Safety Information

Understanding the challenges that you will face when operating a scooter will greatly improve your safety on the roads. There are many things that you can do to protect yourself when riding. You will find many helpful recommendations throughout this manual. Following are a few that we consider most important.

Always Wear Protective Gears

It is a proven fact: helmets significantly reduce the number and severity of head injuries. Always wear helmets, eye protection, sturdy boots, gloves, and other protective gears when riding.

Make Yourself Visible

Some drivers do not see scooters because they do not look for them. To make yourself more visible:

- Wear bright reflective clothing while riding.
- Position yourself in the traffic lane so other drivers can see you.
- Signal before turning or changing lanes.
- Use your horn to alert others on the road.
- Always use headlights while riding, even during daytime.

SAFETY INFORMATION

Ride Within Your Limit

Pushing the limits is a common cause of scooter accidents. Never ride beyond your personal abilities or faster than conditions warrant. Remember that alcohol, drugs, fatigue and inattention can significantly reduce your ability to make good judgments and ride safely.

Keep Your Scooter In Safe Condition

For safe riding, it is important to inspect your scooter before every ride, and perform recommended maintenance in a timely manner.

Loading Limit Guidelines

Your scooter has been designed to carry you and one passenger. When you carry a passenger, you may notice some changes in acceleration and braking. However, as long as you keep your scooter well maintained, with good brakes, you can safely carry loads within manufacturer's recommended weight limit. Exceeding the weight limit or carrying an unbalanced load can seriously affect your scooter's handling, braking, and stability. Improper modifications and poor maintenance can also reduce your safety.

DESCRIPTION

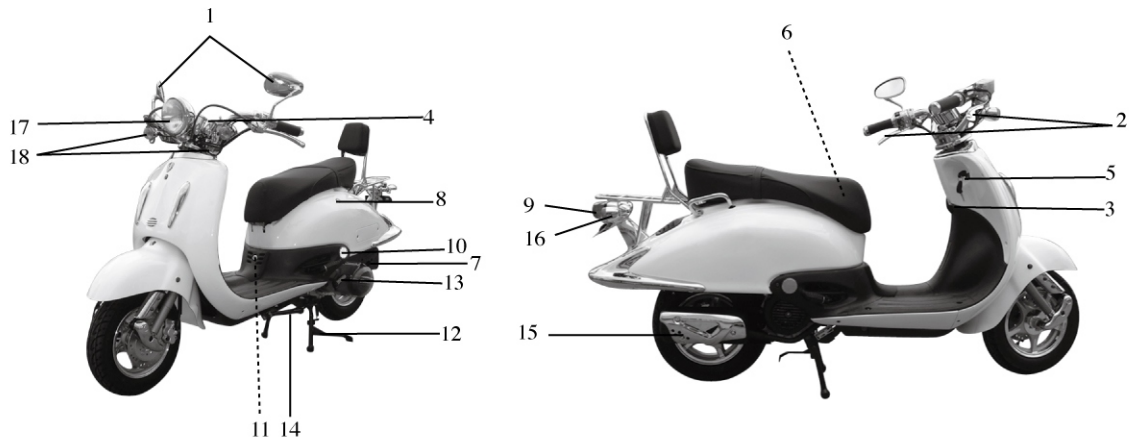

- 1. R and L rear mirror
- 2. R and L brake
- 3. Helmet hook
- 4. Speedometer
- 5. Main switch
- 6. Battery
- 7. Air cleaner

- 8. Seat lock
- 9. Rear light assembly
- 10. R and L reflector
- 11. Oil tank
- 12. Center stand
- 13. Kick starter
- 14. Side stand

- 15. Muffler
- 16. R and L rear turn signal
- 17. Headlights
- 18. L and R turn light

DESCRIPTION

Speedometer

Riding speed is indicated by km/h and mph.

Odometer

The total riding distance is indicated in miles.

The white figures in black background indicate total miles traveled.

Engine Tachometer

Engine tachometer indicates the revolution per minute of the engine.

Indicating lamp of turning light

It flashes when turning light is in use.

Fuel Gauge

Fuel gauge indicates the remaining fuel in the fuel tank (the gauge does not work when main switch is in the “OFF” position). The gauge needle moves from “F” (full) to “E” (empty) as the fuel decreases in the fuel tank. Fill the tank with 90 octane or higher gasoline when the needle is approaching the “E” position. There is no reserve tank.

Indicating lamp of high beam

It indicates high beam is in use.

NOTE:

***Apply low beam to avoid obstructing the view of oncoming drivers and drivers ahead.**

DESCRIPTION

1. Speedometer
2. Odometer
3. Turn signal indicator
4. High beam indicator
5. Fuel gauge

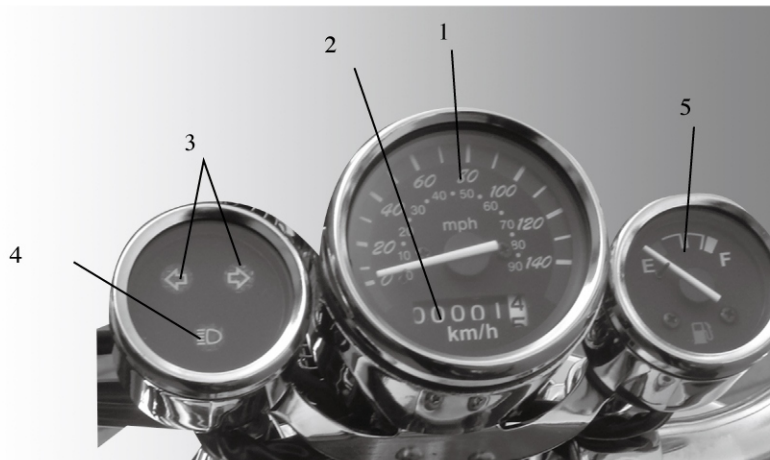

INSTRUMENT CONTROL

Main Switch

“ON” POSITION:

Electrical circuits are switched on. The engine can now be started. The key can not be removed in this position.

“OFF” POSITION:

All electrical circuits are switched off. The engine stops. The key can be removed in this position

“LOCK” POSITION:

The steering is locked when in this position. The key can be removed.



Main Switch



ON



OFF



LOCK

NOTE:

*Do not leave the main switch in “ON” position for an extended period of time when the engine is stopped. The battery may drain itself.

*Lock the steering and remove the key after parking to avoid theft.

INSTRUMENT CONTROL

Steering Lock

Turn the handlebar fully to the left and lock the steering as show below to prevent theft:

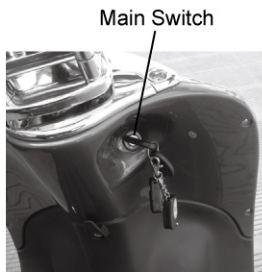

Release the key

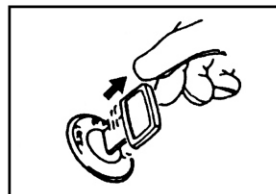

Push the key in when it's in OFF position

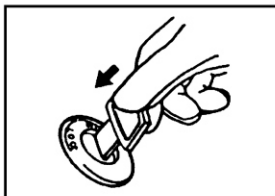

Turn to LOCK position

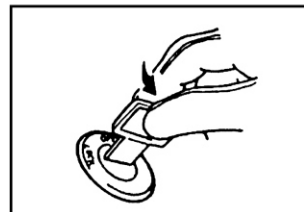

INSTRUMENT CONTROL

Handlebar Switches

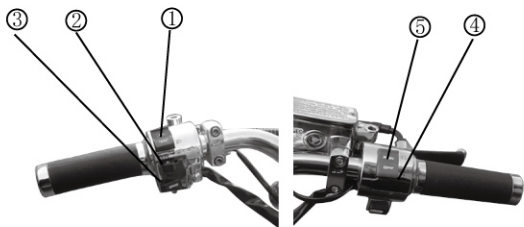

1. Dimmer Switch

When lights switch is in the “ON” position:

☰D :Head light high beam is on.

≡D :Head light low beam is on.

2. Turning Light Switch

To use the turning light while making a turn or change traffic lane, push the switch to ⇨ to signal a right turn. Push the switch to ⇦ to signal a left turn. The switch returns to center

position when released it. The turning light does not go off automatically. To cancel the turning signal, push in the switch after it has returned to center position.

3. Horn Button

The horn sounds by pressing the horn button.

4. Starter Switch

Apply this switch when using electric start.

5. Enging is on ☉

Engine is off ☒

NOTE:

***Release the starter switch immediately after the engine has started. Do not apply starter switch again when the engine is running.**

***Never exceed 4 seconds when using starter switch each time.**

INSTRUMENT CONTROL

Fuel Tank Cap

When gas tank is located underneath the foot rest



①
②
③
Open: ①-②-③

Insert the key, turn clockwise to open the access panel.

Give fuel cap 1/4 of a full turn, in direction counter clockwise to open

Close:

Press the fuel tank cap to close. Turn the key counter clockwise to original position, remove the key.

NOTE:

*The key can not be removed if the fuel tank cap is not locked properly.

Fuel Tank Cap

When gas tank is located underneath the seat cushion.



Open:

Fuel tank is located underneath the seat cushion. To open, turn the brass cap counterclockwise until it unlocks.

Close:

Lock the fuel tank by pressing down on the cap and turning it clockwise.

Seat Lock

To open the seat, insert the key into the lock and turn as shown below. Return the seat to its original position and press down to lock up. Pull up on the seat slightly to ensure it is fully locked.



INSTRUMENT CONTROL

Front Brake Lever

The front brake lever is located on the right handlebar.
Pull the lever to apply front brake.

Front

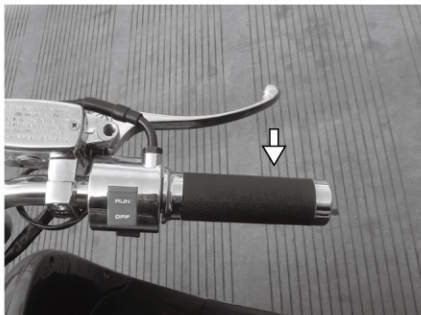

Rear Brake Lever

The rear brake lever is located in left handlebar.
Pull the lever to apply rear brake.

Rear

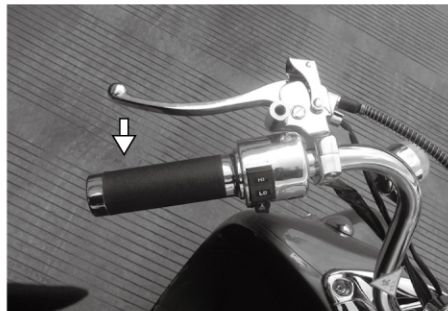

INSTRUMENT CONTROL

Rear Storage Compartment

The compartment is located under the seat. Open the seat to store a helmet in the compartment.

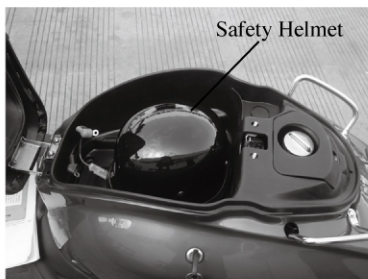

Front Helmet pothook

The helmet hook is used for storing a secondary helmet.



NOTE:

*The maximum loading capacity of rear storage compartment is 5 kg.

PRE-OPERATION CHECKS

Pre-operation Checks

Pre-operation checks should be made each time the scooter is used. Such an inspection can be accomplished in a very short time. The added safety it insures is more than worth the time involved.

Before using this scooter, check the following points:

NO	ITEM	ROUTINE	PAGE
1	Front Brake	Check operation, freeplay, fluid level and fluid leakage. top up with DOT3 brake fluid if necessary.	15,16
2	Rear Brake	Check operation, condition and free play. Adjust if necessary.	15,16
3	Throttle	Check for smooth operation. Adjust if necessary	17
4	Engine Oil	Check engine oil level, add oil if necessary.	17
5	Tires/Wheels	Check tire pressure, wear and damage.	18
6	Fittings/Fasteners	Check all chassis fittings and fasteners. Tighten/adjust if necessary.	20
7	Lights/Signals/Switches	Check operation.	20
8	Fuel	Check fuel oil level, add oil if necessary.	21

PRE-OPERATION CHECKS

Brakes

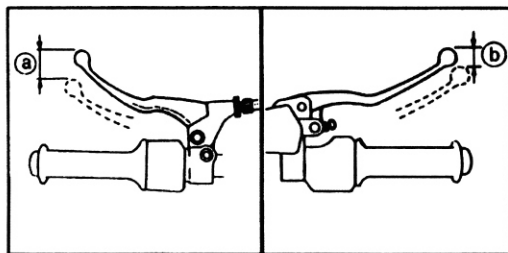

a. Free play 10~20 mm

b. Free play 2~5 mm

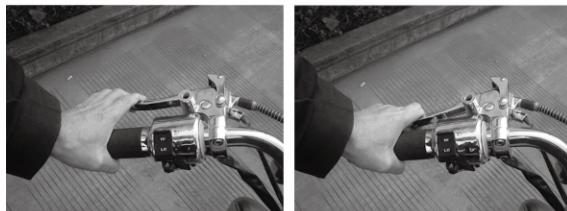

Brake Levers

Check for correct free play in the brake levers and correct them if necessary. Make sure the brakes are working properly by checking at low speed shortly after starting out.

NOTE:

A soft, spongy feel in the brake lever indicates a failure in the brake system. Do not operate the scooter until the failure in the brake system has been corrected. Ask a dealer for immediate repairs.

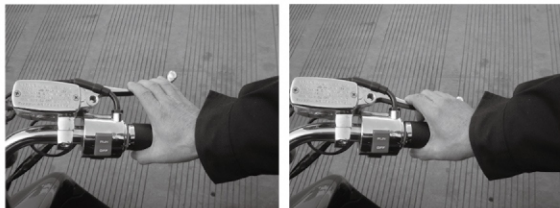

PRE-OPERATION CHECKS



1. Minimum level

Brake Fluid

Check the brake fluid level. Add fluid if necessary.

Recommend brake fluid: DOT3

Brake Fluid Leakage

Apply the brake a few times. Check to see if any brake fluid leaks out from the pipe joints or the master cylinder

NOTE:

***Brake fluid may deteriorate painted surfaces or plastic parts. If spilled, clean it up at once.**

***If brake fluid leakage is found, ask a dealer for immediate repairs. Such leakage could indicate a hazardous condition.**

PRE-OPERATION CHECKS

Throttle Grip

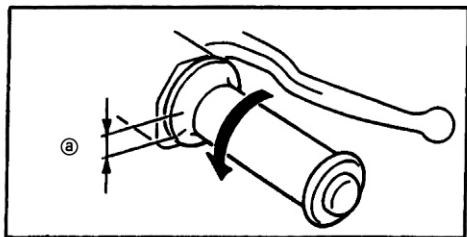

a. Free play 3~5 mm

Turn the throttle grip and check the free play to see if it operates properly. Make sure the grip returns to the original position by spring force when released. Ask your local dealer to make any necessary adjustments.

Engine Oil

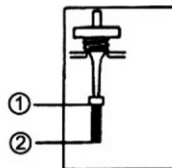

1. Maximum level
2. Minimum level



Make sure the engine oil is at the specified level.
Fill with oil if necessary. (See page 26, 27 for details).

Recommended Engine Oil:

Four stroke engine oil SAE 10W-40

PRE-OPERATION CHECKS

Tires

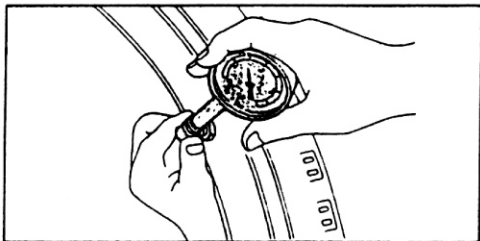

To ensure maximum performance, longer durability, and safe operation, always check and adjust the tire pressure before operating your scooter.

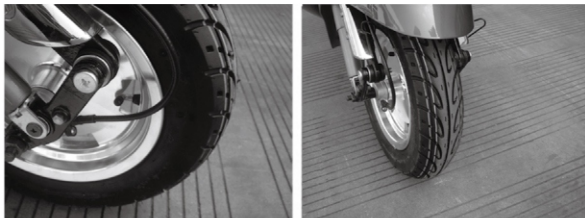

NOTE:

***Tire pressure should be checked and adjusted when tire temperature equals the ambient air temperature. Tire pressure must be adjusted according to the total weight of cargo, rider, passenger, accessories, and vehicle speed. Refer to tire walls for proper inflation pressure.**

PRE-OPERATION CHECKS

Make sure the total weight of the cargo, rider, passenger, and accessories do not exceed the maximum loading limit of your scooter. Operating overloaded scooter could cause tire rupture, an accidents, and injuries.

NOTE:

Proper loading affects several characteristics of your scooter, such as handling, braking, acceleration, and safety. Do not carry loosely packed items that can shift during travel. Securely pack your heaviest items close to the center of your scooter and distribute the weight evenly from side to side. Properly adjust the suspension to your load, and check the condition and pressure of your tires.

Tire Inspection

Always check the tires before operating your scooter. Contact a dealer if center tread depth reaches the limit as show, if the tire has a nail or glass fragments in it, or if the sidewall is cracked, and have the tire immediately replaced.

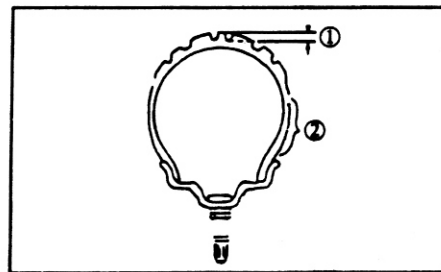

1. Tread depth

2. Side wall

Minimum Tire Tread Depth:

Front: 1.5mm

Rear: 2.0mm

PRE-OPERATION CHECKS

Fittings and Fasteners

Always check the tightness of chassis fittings and fasteners before a ride. Take your scooter to a dealer to correct all fittings and fasteners to proper torque.

Lights, Signals, and Switches

Check all the lights. Make sure they are in working condition. Check the operation of the handlebar switches and the main switch.

Mirror

Adjust mirrors as shown in illustrations below to ensure maximum visibility,

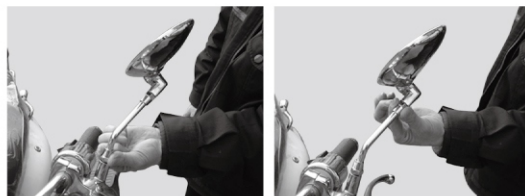

Adjust the rear view mirrors so that when you are seated comfortably on the scooter, you have the best view rear traffic.



PRE-OPERATION CHECKS

Fuel

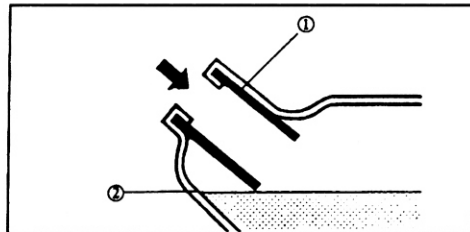

1. Filler tube

2. Fuel level

NOTE:

*Do not fill the fuel tank above the bottom of the filler tube as shown in the illustration. Fuel tank may overflow when the fuel heats up and expands.

*Always wipe off spilled fuel immediately with a dry and clean soft cloth. Fuel may deteriorate painted surfaces or plastic parts.

Recommended Fuel:

90 octanes or higher unleaded gasoline

Fuel Tank Capacity:

Total 4.0 Liter

OPERATION

Start An Engine

*Park before starting.

*Return the side stand to its original position.

*Check if there is sufficient fuel and engine oil.

1. Turn the main switch to ON.



①

②

2. Check to see that engine kill switch is in “RUN” position.

3. Completely release the throttle grip, apply rear brake lever.

4. Push the starter switch. Do not touch the starter switch again once the engine has started.

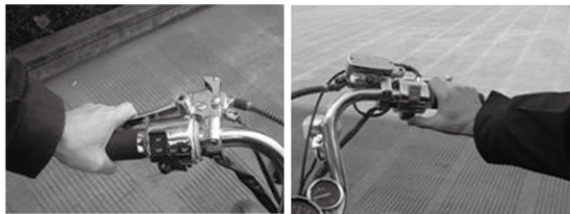

③

④

NOTE:

*If the engine fails to start, release the start switch, wait a few seconds, then try again. Each attempt should not be over 4 seconds to preserve the battery. If the engine has not started after 4-5 attempts, turn the throttle grip 1/8-1/4 turn, then push the starter switch again.

*For an engine which can not be cranked by electric start, or a vehicle which has not been used for a long time, turn on the main switch and throttle grip and apply kick starter to crank the engine.

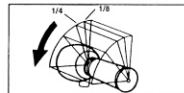

OPERATION

5. For a cold vehicle, preheat the engine for 1-3 minutes before riding.

NOTE:

***For maximum engine life, never accelerate hard with a cold engine.**

***Always return the kick starter to the original position after starting.**

***The exhaust fumes are poisonous and can cause loss of consciousness and even death within a short time. You must operate your scooter in an area with adequate ventilation.**

Starting Off

1. Apply the rear brake lever with your left hand and hold the rear grip with your right hand. Push the scooter off the main stand.
2. Sit astride the seat, with left foot touching the ground to avoid inclination.
3. Release the rear brake lever.
4. Check for oncoming traffic and use your turn signal.
5. Turn the throttle grip slowly and you are off. Remember to turn off the signal after use.

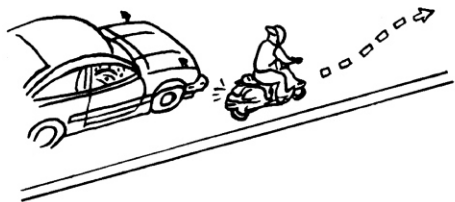

OPERATION

Acceleration

The speed can be adjusted by opening and closing the throttle grip. Turning it toward you increases the speed, while turning it away from you decreases the speed.



Increase



Decrease

Parking

When parking the scooter, stop the engine and turn off the main switch. Remove the key!

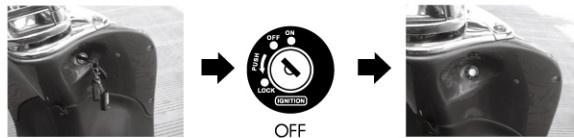

NOTE:

*The muffler is hot after operation. Park the scooter in a place where pedestrians or children are not likely to touch the scooter.

*Do not park the scooter on a slope or soft ground, the scooter may overturn.



OPERATION

Engine Break-in Period

There is never a more important period in the life of your scooter than the period between zero and 1,000 miles. For this reason we ask that you carefully read the following material. You should not place an excessive load on the engine for the first 1,000 miles. The various parts in a new engine wear and polish themselves to the correct operating clearances during this period. Prolonged full throttle operating or any condition that might result in excessive heating of the engine should be avoided.

Keep the riding speed below 55 mph within the first 1,000 miles.

See the following for details:

1. 0-300 miles:

Keep the speed below 35 miles per hour.

2. 300-500 miles:

Keep the speed below 45 miles per hour.

3. 500-1,000 miles:

Keep the speed below 55 miles per hour.

NOTE:

***After 1,000 miles of operation, be sure to replace the engine oil and clean the oil filter. If engine trouble occurs during the break-in period, consult your dealer immediately.**

PERIODIC MAINTENANCE AND REPAIR

Periodic Maintenance and Minor Repair

Periodic inspection, adjustments, and lubrication will keep your scooter in the safest and most efficient condition possible. You must take into consideration that weather, terrain, geographical locations, and a variety of causes all tend to demand that each owner alter the time schedule for regular maintenance to shorter intervals.

The most important points of scooter maintenance: inspection, adjustments, and lubrication are explained in the following pages.

NOTE:

***If you are not familiar with servicing your scooter, consult your local dealer. Your scooter is designed for use on paved road surfaces only. If you operate the scooter in abnormally dusty, muddy, or wet conditions, the air filter should be cleaned or replaced more frequently. Consult your local dealer for proper maintenance intervals.**

PERIODIC MAINTENANCE AND REPAIR

PERIODIC MAINTENANCE CHART

ITEM	RIDING DISTANCE (km)													Daily Checks
	300	1000	2000	3000	4000	5000	6000	7000	8000	9000	10000	11000	12000	
Engine Oil	R	R	R	R	R	R	R	R	R	R	R	R	R	I
Engine Oil Strainer Mesh	C				C				C					C
Gear Oil	R			R			R			R			R	
Spark Plug	Clean at every 2000km, replace if necessary.													
Valve Clearance		A			A				A					A
Cam Chain		A			A				A					A
Carburetor					I				I					I
Air Cleaner	Clean the element at every 2000km and replace at every 5000km.													
Electrolyte of Battery		I	I	I	I	I	I	I	I	I	I	I	I	I
Fuel Strainer Mesh	Clean at every 1000km, replace if necessary.													
Brake System		I	I	I	I	I	I	I	I	I	I	I	I	I
Drive Belt														
Screws and Nuts of Each Part	T					T						T		
Concentration of Waste Gas	Regularly check and adjust.													
*Follow on the analogy of the distance intervals listed above if exceeds the listed number.														
*If often ride in dusty area, element of air cleaner should be cleaned or replaced more frequently.														

I: Check, clean, lubricate, adjust or replace if necessary **A:** Adjust **C:** Clean **R:** Replace **T:** Tighten

PERIODIC MAINTENANCE AND REPAIR

Engine Oil

1. Oil Level Measurement

- a. Place the scooter on the center stand. Warm up the engine for several minutes.
- b. Stop the engine and wait a few minutes until the oil levels before removing the dipstick.
- c. The oil level should be between the minimum and maximum mark on the dipstick. If the level is low, add oil to raise it to the specified level.

NOTE:

***Be sure your scooter is positioned straight up when checking oil level. A slight tilt toward the side can result in false reading.**

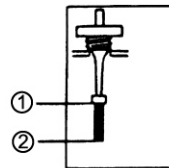

1. Maximum level

2. Minimum level



PERIODIC MAINTENANCE AND REPAIR

2. Engine oil replacement

Replace engine oil after the initial 300 miles. Thereafter, replace engine oil every 1,000 miles. Check the oil level after every 500 miles. Add oil to specified level if necessary.

3. Start the engine and warm up for a few minutes. While warming up, check for oil leakage. If oil leakage is found, stop the engine immediately and check for the cause.

Follow the steps outlined below to change engine oil:

- a. Warm up the engine for a few minutes.
- b. Stop the engine. Place an oil pan under the engine and remove the dipstick.
- c. Remove the drain plug and drain the oil.
- d. Clean the oil filter with solvent.
- e. Reinstall the oil filter and drain plug.
- f. Fill the engine with oil and install the dipstick.

NOTE:

***If your scooter is often ridden on bumpy roads, in cold weather, or for short distances, engine oil should be replaced sooner than prescribed by this manual. Consult your local dealer for recommendations.**

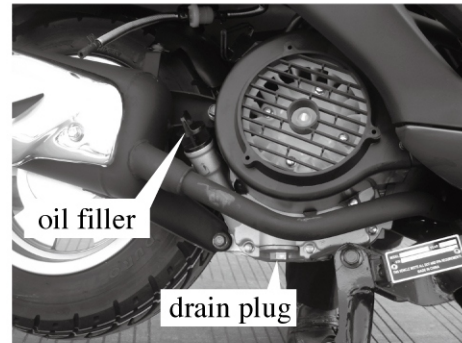

PERIODIC MAINTENANCE AND REPAIR

Gear Oil Replacement

Replace the gear oil after the initial 300 miles.

Thereafter, replace oil again every six months or 3,000 miles, whichever occurs first.

Do As Below Described For Replacement:

1. Put the scooter on the center stand.
2. Place an oil pan under the gear case.
3. Remove the oil filler bolt and the drain plug to drain the oil.
4. Reinstall and tighten the drain plug.
5. Fill the gear case with oil.
6. Reinstall the oil filler bolt.
7. After replacing the gear oil, be sure to check for oil leakage.

Recommended oil: SAE 10W40

NOTE:

***Do not let foreign materials enter the gear case. Be sure oil does not get on the back tire or wheel.**

PERIODIC MAINTENANCE AND REPAIR

Cleaning of Air Filter

The air filter should be cleaned at the specified intervals. It should be cleaned more frequently if you often ride in wet or dusty areas.

1. Place the scooter on the center stand.
2. Remove the left side panel by removing the screws on it.
3. Remove the air filter cover by removing screws on it.
4. Take out the air filter and remove the screws on it.
5. Remove the air filter element and wash gently, but thoroughly in solvent. Replace air filter if it is damaged.
6. Squeeze out excess solvent, and dry it.
7. Apply oil to the entire surface of the air cleaner and squeeze out the excess oil. It should be damp, but not dripping.
8. Reinstall the air filter and the air filter cover.

Recommend oil: Same as engine oil.

NOTE:

***Drain the oil accumulated in the clear tube after every 1,000 miles.**

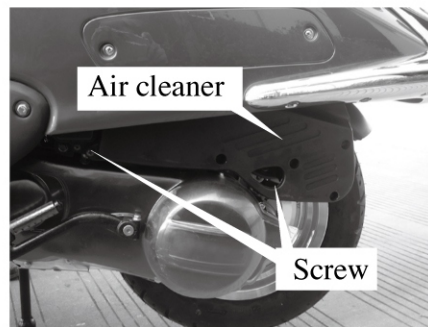

PERIODIC MAINTENANCE AND REPAIR

Spark Plug Inspection

The spark plug is an important engine component. The condition of the spark plug can indicate the condition of the engine. Therefore, you should periodically inspect it for signs of deterioration. The ideal color on the white insulator around the center electrode is a medium to light tan color for a scooter that is being ridden normally.

Deposits will cause the spark plug to slowly break down and erode. You should replace the spark plug if electrode erosion becomes excessive, or if carbon and other deposits become excessive. Before installing the spark plug, measure the electrode gap with a wire thickness gauge. Adjust the gap to the specification.

Spark Plug Gap: 0.8mm

When installing the plug, always clean the gasket surface. Wipe off any grime from the threads. Tighten the spark plug with your fingers first, then finish tightening with a wrench.

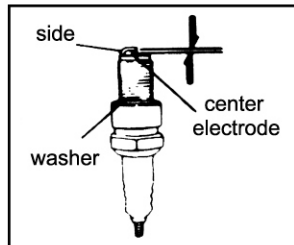

PERIODIC MAINTENANCE AND REPAIR

Brake Lever Free Play Adjustment

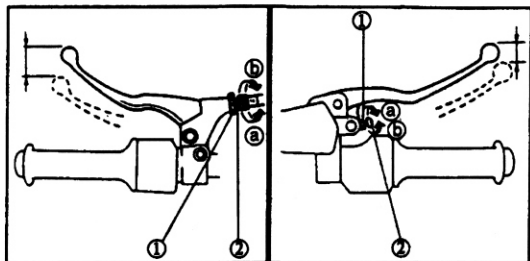

1.Locknut

2.Adjusting bolt

Loosen the locknut and turn the adjusting bolt in direction A to increase free play, in direction B to decrease free play. Be sure to tighten the locknut after adjustments.

NOTE:

When it is not impossible to make the proper adjustments on your own, consult your local dealer for professional guidance.

The front brake lever free play should be adjusted to 2-5mm at the brake lever end.

The rear brake lever free play should be adjusted to 2-5mm at the brake lever end.

PERIODIC MAINTENANCE AND REPAIR

Inspection of Brake Fluid Level

Insufficient brake fluid may allow air to enter the brake system, possibly causing the brakes to become ineffective. Before riding, check that the brake fluid is above the minimum level and fill when necessary.

Observe These Precautions:

1. When checking the brake fluid level, make sure the top of the master cylinder is leveled.
2. Use only the designated brake fluid. Otherwise, the rubber seals may deteriorate, causing leakage and poor brake performance. **Recommended Brake Fluid:** DOT3
3. Refill with the same type of brake fluid. Mixing fluid may result in a harmful chemical reaction and lead to poor brake performance.
4. Be careful that water does not enter, which may result in vapor lock.
5. Brake fluid may deteriorate painted surfaces and plastic parts. Always clean up the spilled fluid immediately.
6. Have a dealer check the cause if brake fluid level goes down.

PERIODIC MAINTENANCE AND REPAIR

Brake Fluid Replacement

1. Complete fluid replacement should be done only by trained personnel.
2. Have a dealer replace the following components during periodic maintenance or when they are damaged or leaking.
 - a. Replace all rubber seals every two years.
 - b. Replace all hoses every four years.

Brake Lever Lubrication

Lubricate the pivoting parts of both brake levers.

Recommended lubricant:

SAE 10W40 motor oil

Cable Inspection and Lubrication

Inspect the inner cable and the cable end. If it does not operate smoothly, ask a dealer to replace them.

NOTE:

***Damage to the outer housing of cables may allow internal rusting and cause interference with cable movement. Replace damaged cables as soon as possible to prevent unsafe conditions.**

Recommended lubricant:

SAE 10W40 motor oil

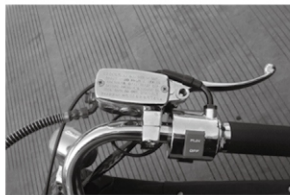

PERIODIC MAINTENANCE AND REPAIR

Center and Side Stand Lubrication

Lubricate the pivoting and mating joints. Check to see that the center and side stand move up and down smoothly.



Side stand



Center stand

Recommended lubricant:

SAE 10W40 motor oil

NOTE:

*If the center or side stand does not move smoothly, consult a dealer.

PERIODIC MAINTENANCE AND REPAIR

Front Fork Inspection

Securely support the scooter so there is no danger of it falling over.

1. Visual Check:

Check for scratches or damage on the inner tube and excessive oil leakage from the front fork.

2. Operation Check:

Place the scooter on a level place.

a. Hold the scooter in upright position and apply the front brake.

b. Push down hard on the handlebars several times and check if the fork rebounds smoothly.

NOTE:

***If any damage or jerky movement is found with the front fork, consult your local dealer.**



PERIODIC MAINTENANCE AND REPAIR

Steering Inspection

Periodically inspect the condition of the steering. Worn out or loose steering bearings may be dangerous. Place a stand under the engine to raise the front wheel off the ground. Hold the lower end of the front forks and try to move them forward and backward. If any free play can be felt, ask a dealer to inspect and adjust the steering. Inspection is easier if the front wheel is removed.

NOTE:

***Securely support the scooter so there is no danger of it falling over.**

Wheel Bearings

If there is play in the front or rear wheel hub or if the wheel does not turn smoothly, have a dealer inspect the wheel bearings.

PERIODIC MAINTENANCE AND REPAIR

Fuse Replacement

If the fuse is blown, turn off the main switch and the switch of the circuit in question. Remove the screws on battery case cover. The fuse is at the side of the case. Install a new fuse of specified amperage. Make sure the new fuse is fitted securely. Turn on the switches and see if the electrical device operates.

Specified Fuse: 15A

NOTE:

***Do not use fuses of higher amperage rating than those specified. Substitution of fuse of improper rating can cause extensive electrical system damage and possibly a fire.**

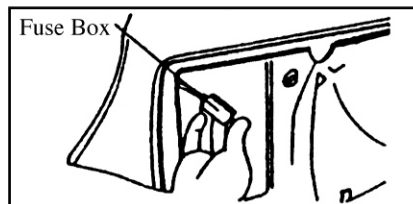

PERIODIC MAINTENANCE AND REPAIR

Battery

This scooter uses sealed and non-replenishable type battery. It is unnecessary to check and add liquid.

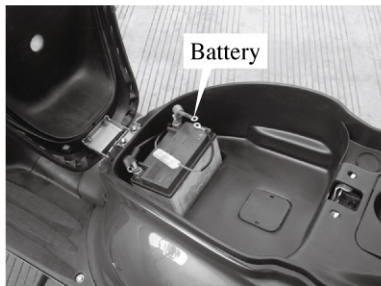

NOTE:

*The battery will lose its charge if the scooter is not operated for an extended period of time. Remove the battery from the scooter and charge it fully when not in use. Store it in a place with adequate ventilation.

Battery Joint:

1. Remove the battery before cleaning the joint of it.
2. Clean the joint first, then apply a thin coat of vasoline on it. Reinstall the battery.

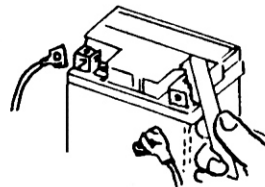

NOTE:

- *Avoid near by live fire when removing or installing the battery.
- *When removing the battery, turn off the main switch, remove the negative pole wire first, then the positive pole wire. Change the order when reinstalling (positive wire first, then negative wire).

ELECTRIC CIRCUIT DIAGRAM

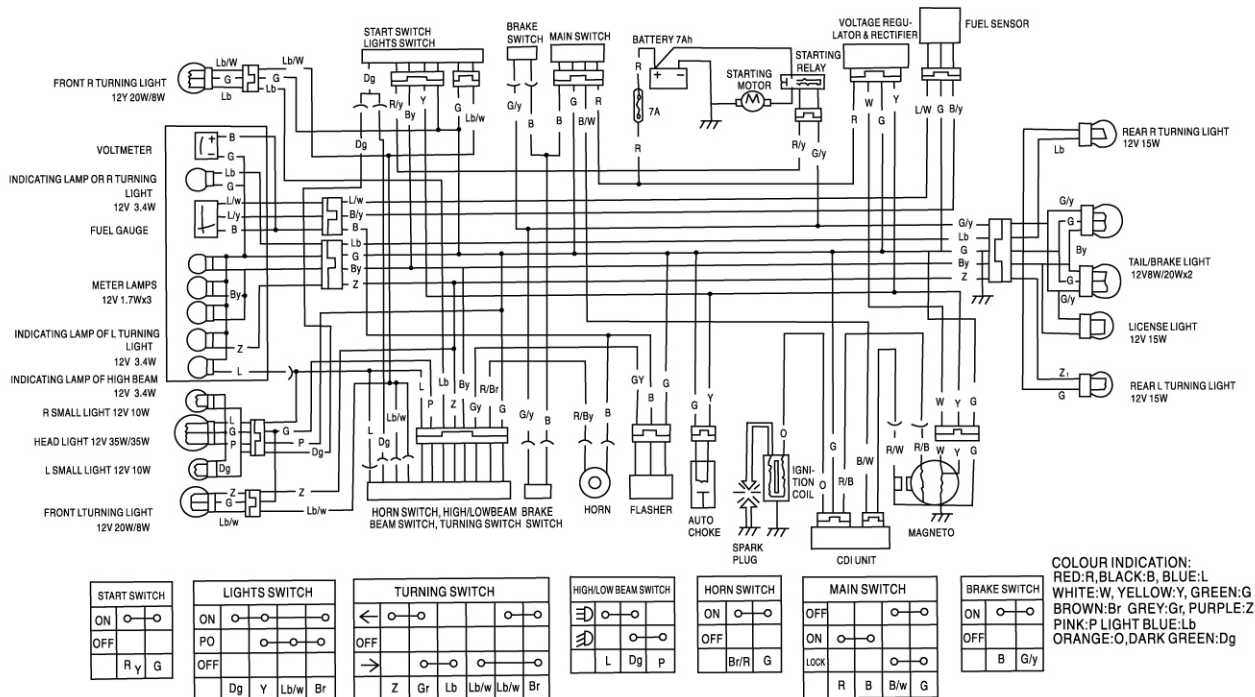

Specification

	Model		Engine cod	BN157QMJ
Item	Specification	Heritage 150		
Length	1875mm		Front shock absorber	Telescopic fork
Width	880mm		Rear shock absorber	Unit swing
Height	1090mm		Clutch type	Auto centrifugal clutch
Wheel base	1270 mm		Transmission	C.V.T.
Net Weight	94kg (Front:32kg Rear:62kg)		Front tire	3.50-10
Model	Single cylinder,4- stroke, forced air cooled engine		Rear tire	3.50-10
Fuel required	90 or higher		Rim type	MT2.50x10 (Aluminum)
Displacement	149.6 ML		Tire pressure	Front 175kPa (25.2PSI) Rear 225kPa (32.4PSI)
Compression ratio	9.5: 1		Front brake	Disk type (Ø 190 mm)
Maximum HP	6.3kw/7500r/min		Rear brake	Drum type (Ø 110 mm)
Maximum torque	8.8N. m/6000r/min		Head lamp(high, low)	12V 35W
Valve clearance: IN/EX	inlet: 0.10~0.12mm, outlet: 0.10~0.12mm		Front position lamp	12V 3W
Starting methods	electrical starter		Front/ Rear direction indicator	12V 10W
Engine oil capacity	0.80 L (0.60L for change)		Rear position lamp/Stop lamp	12V 21W/5W
Transmission oil capacity	0.12L (0.11Lfor change)		Licence light	/
Fuel tank capacity	5.0L±0.2 L		Battery capacity	12V 6Ah
Fuse	15A		Air cleaner	Paper type
Spark plug	CR7HSA			

PERIODICAL MAINTENANCE SCHEDULE

Code:

I ~ Inspection, cleaning, and adjustment R ~ Replacement C ~ Cleaning (replaced if necessary) L ~ Lubrication

Item	Maintenance kilometer		300KM	Every 1000KM	Every 3000KM	Every 6000KM	Every 12000KM	Remarks
	Check Items	Maintenance Interval	NEW	1 Month	3 Months	6 Months	1 Year	
1	Air cleaner element (Remark)		I	C		R(paper)	R(sponge)	
2	Air cleaner		I					
3	Oil filter (Screen)		C			C		
4	Engine oil		R	Replacement for every 1000KM				
5	Fuel pump filter			Replacement for every 10000KM				
6	Tire, pressure		I	I				
7	Battery		I	I				
8	Spark plug		I		I		R	
9	Carburetor (idle speed)		I			I		
10	Steering bearing and handles		I		I			
11	Check transmission for leakage		I	I				
12	Check crankcase for leakage		I	I				
13	Transmission oil		R	Replacement for every 5000KM(5 Months)				
14	Drive belt/roller					I	R	
15	Fuel tank switch and lines		I		I			
16	Throttle valve operation and cable		I	I				
17	Engine bolts and nuts		I		I			
18	Cylinder head, cylinder, and piston					I		
19	Exhaust system/cleaning carbon					I		
20	Cam Chain/ignition time		I		I			
21	Valve clearance		I			I		
22	Shock absorbers		I			I		
23	Front/rear suspension		I			I		
24	Main/side stands		I			I/L		
25	Crankcase Blow-by system(PCV)		I		I			
26	Clutch disk					I		
27	Brake mechanism/brake lining (pad)		I	I				
28	Bolts/nuts for each components		I	I				

☆The above maintenance schedule is established by taking the monthly 1000 kilometers as a reference which ever comes first.

Remark: 1.Clean or replace the air cleaner element more often when the scooter is operated on dusty roads or in the Heavily- polluted environment.

2.Maintenance should be performed more often if the scooter is frequently operated in high speed and after the scooter has accumulated a higher mileage.

EMISSION CONTROL SYSTEM WARRANTY

Your new BMS vehicle complies with the U.S. EPA, and State of California emission regulations (models certified for sale in California only). BMS MOTORSPORTS,INC. provides the emission warranty coverage for engines in the United States and its territories. In the remainder of this Emission Control System Warranty, BMS MOTORSPORTS,INC. will be referred to as BMS

YOUR WARRANTY RIGHTS AND OBLIGATIONS

The California Air Resources Board and BMS are pleased to explain the emission control system warranty on your 2020 Highway Motorcycle - 1b (50-169cc). In California, new motor vehicles must be designed, built and equipped to meet State's stringent anti-smog standards. BMS must warrant the emission control system on your motorcycle for the periods of time listed below provided there has been no abuse, neglect or improper maintenance of your motorcycle.

Your emission control system may include parts such as the carburetor or fuel injection system, the ignition system, catalytic converter and engine computer, if it is equipped. Also included may be hoses, belts, connectors and other emission-related assemblies.

Where a warrantable condition exists, BMS will repair your motorcycle at no cost to you including diagnosis, parts and labor.

MANUFACTURER'S WARRANTY COVERAGE

The 2020 and later model year highway motorcycle are warranted for 12,000 km or for 5 years, whichever comes first. If any emission-related part on your vehicle is defective, the part will be repaired or replaced by BMS. This is your emission control system DEFECTS WARRANTY.

OWNER'S WARRANTY RESPONSIBILITIES

As the vehicle owner, you are responsible for the performance of the required maintenance listed in your owner's manual. BMS recommends that you retain all receipts covering maintenance on your vehicle, but BMS cannot deny warranty solely for the lack of receipts or for your failure to ensure the performance of all scheduled maintenance.

You are responsible for presenting your vehicle to the BMS' dealer as soon as a problem exists. The warranty repairs should be completed in a reasonable amount of time, not to exceed 30 days. As the vehicle owner, you should be aware that BMS may deny your warranty coverage if your vehicle or a part has failed due to abuse, neglect, improper maintenance or unapproved modifications.

If you have any questions regarding your warranty rights and responsibilities, you should contact BMS MOTORSPORTS,INC. 1151 Spruce St, Riverside Ca 92507 TEL 951-274-9267 or (for California registered highway vehicles only) the California Air Resources Board at 9528 Telstar Avenue, El Monte, CA 91731-8001.

WARRANTY COVERAGE

BMS warrants that each new 2020 and later BMS motorcycles:

- A. is designed, built and equipped so as to conform at the time of initial retail purchase with all applicable regulations of the United States Environmental Protection Agency, and the California Air Resources Board; and
- B. is free from defects in material and workmanship which cause such vehicle to fail to conform with applicable regulations of the United States Environmental Protection Agency or the California Air Resources Board for the periods specified above.

The emission control system warranty period for this vehicle begins on the date the vehicle is delivered to the first purchaser other than an authorized dealer, or the date it is first used as a demonstrator, lease, or company vehicle, whichever comes first and continues for the period of time listed above. This warranty is transferable to each subsequent purchaser for the duration of the warranty period.

Warranty repairs will be made without charge for diagnosis, parts, or labor. All defective parts replaced under this warranty become the property of BMS. A list of warranted parts is included in this warranty statement. Normal maintenance items, such as spark plugs and filters, that are on the warranted parts list are warranted up to their required replacement interval only.

Only BMS approved replacement parts may be used in the performance of any warranty repairs and must be provided without charge to the owner. The use of replacement parts not equivalent to the original parts may impair the effectiveness of your engine emission control system. If such a replacement part is used in the repair or maintenance of your engine, and an authorized BMS dealer determines it is defective or causes a failure of a warranted part, your claim for repair of your engine may be denied. If the part in question is not related to the reason your engine requires repair, your claim will not be denied.

TO OBTAIN WARRANTY SERVICE

You must take your BMS Vehicle, along with your sales receipt or other proof of original purchase date, at your expense, to any BMS dealer who is authorized by BMS to sell and service that BMS product during his normal business hours. Claims for repair or adjustment found to be caused solely by defects in material or workmanship will not be denied because the vehicle was not properly maintained and used.

Repair or replacement of any warranted part is performed at no charge at a warranty station, except in an emergency situation. An emergency occurs when a warranted part or a warranty station is not reasonably available to the owner. In an emergency, repairs may be performed at any available service establishment, or by any individual, using any replacement part. The manufacturer will reimburse the owner for the expenses, including diagnostic charges, not to exceed the manufacturer's suggested retail price for all warranted parts replaced and labor charges based on the manufacturer's recommended time allowance for the warranty repair and the geographically appropriate hourly labor rate. The owner may reasonably be required to keep receipts and failed parts in order to receive compensation. A part not available within 30 days, or a repair not complete within 30 days also constitutes an emergency.

If you are unable to obtain warranty service, or are dissatisfied with the warranty service you received, contact the owner of the dealership involved. Normally this should resolve your problem. However, if you require further assistance, write or call the BMS MOTORSPORTS, INC. Customer Service Department.

EXCLUSIONS AND LIMITATIONS

This Emission Control System Warranty shall not cover any of the following:

- A.** Repair or replacement as a result of
 - (1) accident,
 - (2) misuse,
 - (3) repairs improperly performed or replacements improperly installed,
 - (4) use of replacement parts or accessories not conforming to BMS' specifications which adversely affect performance and/or
 - (5) use in competitive racing or related events.
- B.** Inspections, replacement of parts and other services and adjustments required for required maintenance.
- C.** Any vehicle equipped with an odometer or hour meter on which the odometer mileage or hour meter reading has been changed so that actual mileage cannot be readily determined.

LIMITED LIABILITY

- A.** The liability of BMS under this emission control system warranty is limited solely to the remedying of defects in material or workmanship by an authorized BMS dealer at its place of business during customary business hours. This warranty does not cover inconvenience or loss of use of the vehicle or transportation of the vehicle to or from the BMS dealer. BMS shall not be liable for any other expenses, loss or damage, whether direct, incidental, consequential or exemplary arising in connection with the sale or use of or inability to use the vehicle for any purpose. Some states do not allow the exclusion or limitation of any incidental or consequential damages, so the above limitations may not apply to you.
- B.** No express emission control system warranty is given by us except as specifically set forth herein. Any emission control system warranty implied by law, including any warranty of merchantability or fitness for a particular purpose, is limited to the express emission control system warranty terms stated in this warranty. The foregoing statements of warranty are exclusive and in line of all other remedies. Some states do not allow limitations on how long an implied warranty lasts so the above limitations may not apply to you.

SYSTEMS COVERED BY THIS WARRANTY:	PARTS DESCRIPTION:
Fuel Metering	Carburetor assembly (includes starting enrichment system)
Evaporative	Fuel tank, Fuel cap, Fuel hoses, Carbon canister, Canister mounting brackets, Fuel hose joint, Canister purge hose joint
Exhaust	Catalytic Convertor
Air Induction	Air filter housing, Air filter element*
Ignition	Ignition coil assembly, Ignition control module, Spark plug cap, Spark plug*
Crankcase Emission Control	Crankcase breather tube
Miscellaneous Parts	Tubing, fittings, seals, gaskets, and clamps associated with these listed systems.

